

World Class Performance
in Abrasive, Scaling and
Corrosive Slurries, Sludge,
Liquids, and Bulk Solids

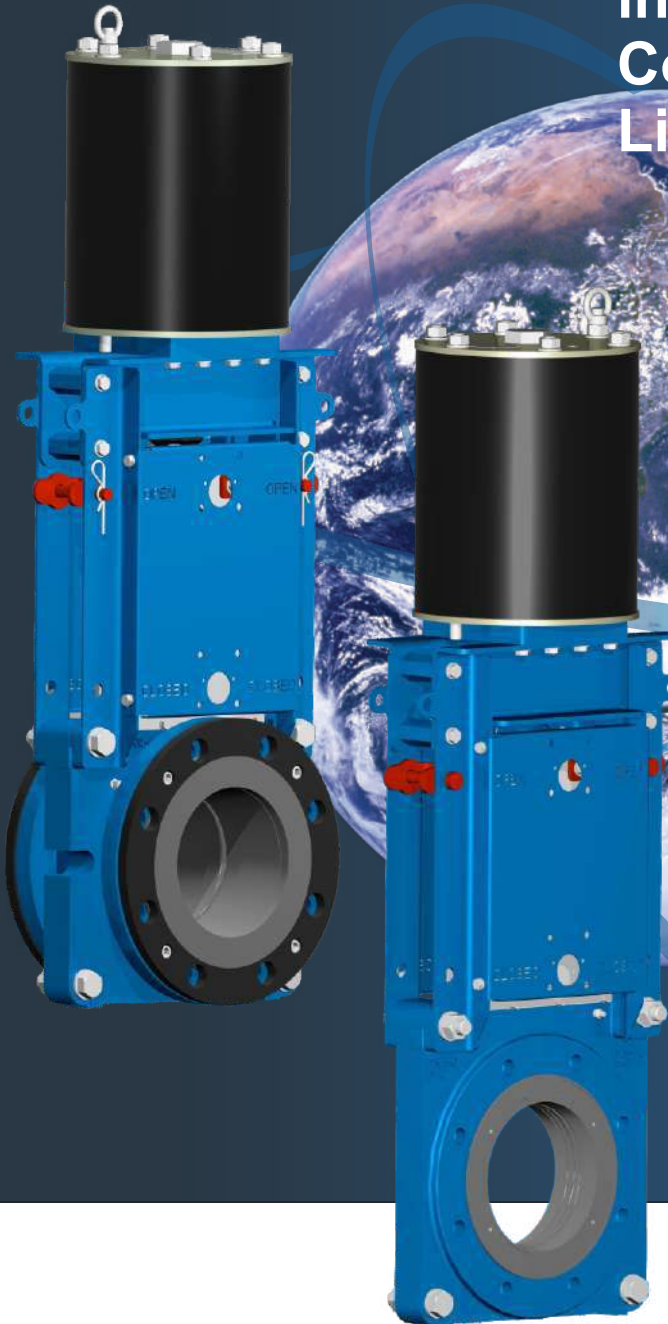

INSAMCOR SKG-F, SKG-W & SKG-LB
Flanged, Wafer and Large Bore Slurry Knife Gate Valves



INSAMCOR® SKG F (Flanged)



INSAMCOR® SKG W (Wafer)

INSAMCOR's purpose is to solve typical and perennial valve problems. We achieve this by providing quality valves that provide the lowest cost of ownership and operation, highest reliability and minimum lifetime maintenance.

INSAMCOR SKG range of wafer and flanged knife gate valves features a packingless design, replaceable elastomer sleeves and a fully enclosed yoke for severe slurry applications.

Design Features and Advantages

- ✓ Bi-directional flow and shut-off resulting in zero downstream leakage
- ✓ No metal parts in contact with the flowing media when the valve is in the fully open position
- ✓ No seat cavity for unwanted solids to build-up and prevent full gate closure
- ✓ Field replaceable heavy duty elastomer sleeves
- ✓ Suitable for wet or dry service
- ✓ 3" - 24" / DN80 - DN600 standard pressure rating of 150PSI CWP (10 bar)
- ✓ 28" - 48" / DN700 - DN1200 standard pressure rating of 90PSI CWP (6 bar) with 150PSI CWP (10 bar) available on request.

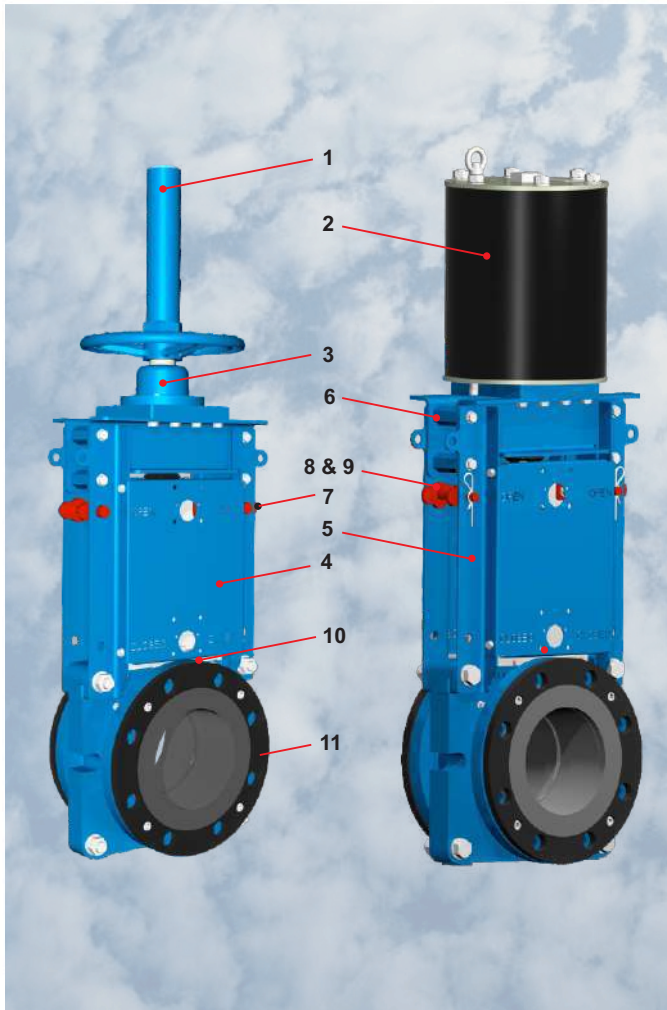

Features (3" - 24" / DN80 - DN600)

1. **Spindle Cover** - to protect the spindle against slurry splatter.
 2. **Actuators** - pneumatic, electric and hydraulic cylinder, manual bevel gear and hand wheel with rising stem
 3. **Thrust housing assembly** - generous oversizing of the thread length of the gunmetal (LG2) thrust nut ensures lowest possible thread loading for longevity. Sizes 12"(DN300) to 16"(DN400) comes standard with thrust bearings and smaller sizes are fitted with vesconite thrust pads.
 4. **Cover plate** - design consists of two cover plates that enclose the gate, spindle and clevis. Light weight for easy removal upon servicing and maintenance.
 5. **Heavy Duty Frame** - heavy duty frame to handle higher thrust associated with Large Bore installations.
 6. **Open supports** - ease of maneuvering valve during installation
 7. **Steel proximity switch covers** - to prevent damage during transport and operation.
 8. **Indicator** - open and close indicators (standard)
 9. **Lockout** - provision for lockouts in the open and closed position (available on sizes 3" - 24")
 10. **Wiper blade** - retains internal lubricants.
 11. **Retainer flange** - standard on the SKG F range
- Washout chamber** - closure plate with flush-out connection (optional)
- * **Standard bellows** - provide additional protection for the spindle against scoring from abrasive particles

Note: '*' not shown in image

INSAMCOR® SKG-F Specifications

The heavy duty slurry knife gate valve shall be a flanged, bi-directional valve with a packingless design. The full port bore shall be formed by two heavy duty elastomer sleeves. one on either side of the gate. Each sleeve shall have a J-ring design stiffener to maintain the shape of the sleeve. Upon closing, the gate will progressively separate the sleeves and once fully closed, will form a bubble tight seal with the upstream sleeve. The yoke shall consist of two yoke plates that fully enclose the gate, spindle and clevis to protect these components from slurry splatter. The yoke design will allow for easy mounting of proximity or limit switches. Steel proximity switch covers must be provided to prevent damage during transport and operation. Provision must be made for lockouts in the open and closed position with open and closed indicators. The top bracket must accept manual, pneumatic or electric actuation for easy conversion in the field.

INSAMCOR® SKG-W Specifications

The heavy duty slurry knife gate valve shall be a wafer style, bi-directional valve with a packingless design. The full port bore shall be formed by two heavy duty elastomer sleeves, one on either side of the gate. The roundness of the sleeve shall be maintained by an embedded stiffener ring near the sealing face and a steel disc on the mating face. Upon closing, the gate will progressively separate the sleeves and once fully closed, will form a bubble tight seal with the upstream sleeve. The yoke shall consist of two yoke plates that fully enclose the gate, spindle and clevis to protect these components from slurry splatter. The yoke design will allow for easy mounting of proximity or limit switches. Steel proximity switch covers must be provided to prevent damage during transport and operation. Provision must be made for lockouts in the open and closed position with open and closed indicators. The top bracket must accept manual, pneumatic or electric actuation for easy conversion in the field.

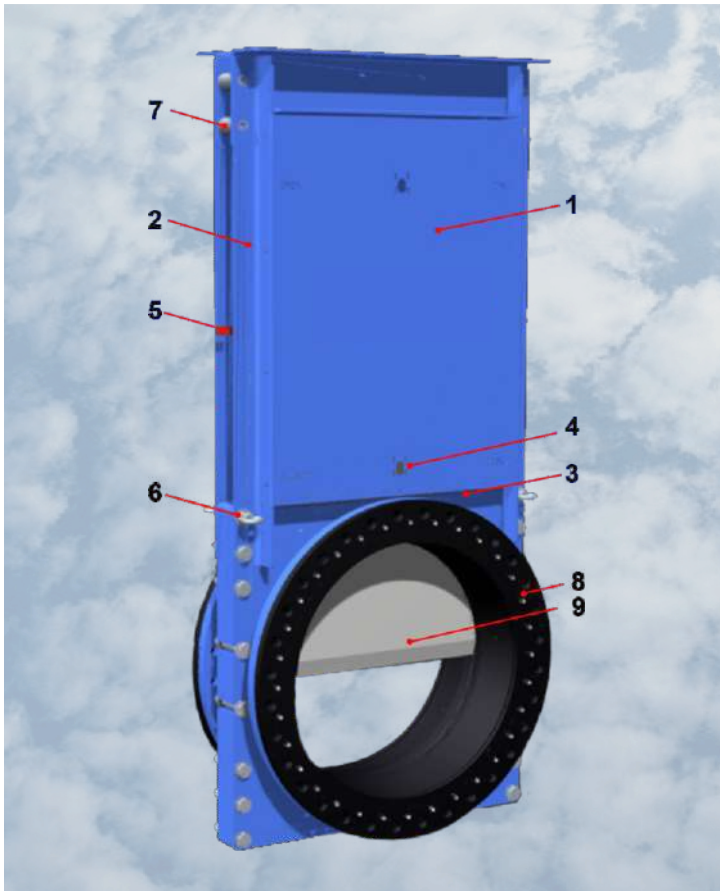

Features (28" - 48"/DN700 - DN1200)

1. **Cover plate** - design consists of two cover plates that enclose the gate, spindle and clevis. Light weight for easy removal upon servicing and maintenance.
 2. **Heavy Duty Frame** - heavy duty frame to handle higher thrust associated with Large Bore installations.
 3. **Wiper blade** - easy, replaceable wiper blade to prevent outside contaminants from getting inside the valve and to maintain internal lubricants.
 4. **Steel proximity switch covers** - to prevent damage during transport and operation
 5. **Indicator** - open and close indicators (standard)
 6. **Lifting lugs** - eye bolts situated on four locations for ease of installation and storage
 7. **Open supports** - ease of maneuvering valve during installation
 8. **Retainer flange** - standard on the SKG F for sizes 3" (DN80) to 48" (Dn1200)
 9. **Gate** - Standard gate material is 316L for 90PSI/6 Bar pressure rating, with SAF2205 as an additional option for 150PSI/10 Bar pressure rating
- * **Spindle cover** - to protect the spindle against slurry splatter
 - * **Actuators** - pneumatic, electric and hydraulic

Note: '*' not shown in image

INSAMCOR® SKG-LB Specifications

The heavy duty slurry knife gate valve shall be a flanged, bi-directional valve with a packingless design. The full port bore shall be formed by two heavy duty elastomer sleeves, one on either side of the gate. Each sleeve shall have an integrally moulded encapsulated stiffener ring to maintain the shape of the sleeve. Upon closing, the gate will progressively separate the sleeves and once fully closed, will form a bubble tight seal with the upstream sleeves. The yoke shall consist of two cover plates and four heavy duty angular supports, that fully enclose the gate, spindle and clevis to protect these components from slurry splatter. The yoke design will allow for easy mounting of proximity or limit switches. Steel proximity switch covers must be provided to prevent damage during transport and operation. The top bracket must accept pneumatic, electric or hydraulic actuation for easy conversion in the field. The valve shall have lifting lugs close to the centre of gravity of the valve with open supports at the top of the yoke for ease of maneuvering during installation and storage.

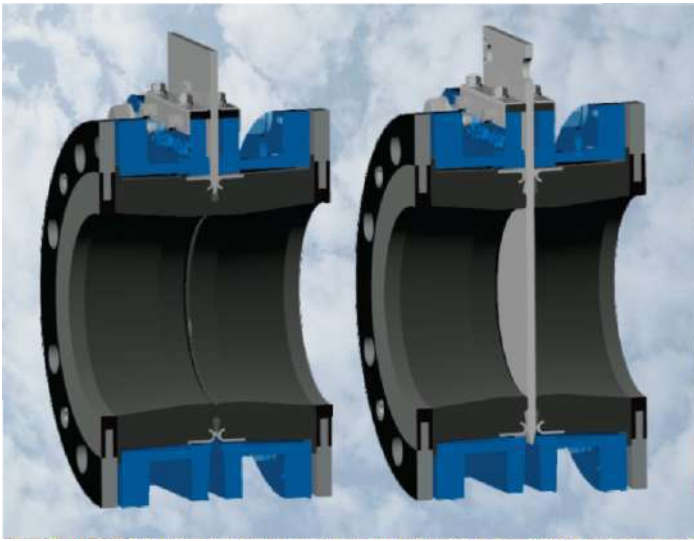

SKG-F in Open and Closed Position

Sealing Principle

When the valve is fully opened the two identical elastomer sleeves push against each other to form a cavity free, bubble tight seal to contain the line pressure.

When the gate moves from the open to closed position, the gate separates the facing sleeves until it completely closes and seals the bore from both directions.

The INSAMCOR SKG-F valve utilizes a J-ring design with stiffener lugs to maintain the rounded shape of the sleeves during opening and closing

Specifications

Size Range

3" - 24" (DN80 - DN600)

Pressure Rating

150PSI CWP (10 bar)

Body & Yoke

Fusion bonded epoxy coated ductile iron body with fusion bonded epoxy coated mild steel yoke plates

Sleeves

Natural rubber standard

Gate

316L stainless steel standard

Retainer/Counter Flanges

Natural rubber encapsulated mild steel

Flange Drilling

ANSI B16.5 Class 150

AS 2129 Table D & E

PN10 & PN16



SKG-W in Open and Closed Position

The rounded shape of the INSAMCOR SKG-W sleeve is maintained by an embedded stiffener ring located near the seating face and a steel disc on the mating face. Flexibility in the axial direction is achieved through the provision of a 360 groove located along the inner surface of the sleeve, which allows the rubber displaced by the closing gate to move axially.

Optional

Pressure Rating

Optional gate materials can be used to increase the pressure rating if the INSAMCOR SKG-F and INSAMCOR SKG-W depending on the valve size and application - please consult the factory

Sleeves

EPDM, CR or NBR

Gate

DUPLEX 2205, Titanium-Gr-2

Actuators

Manual, manual bevel gear, pneumatic, electromechanical and hydraulic

Retainer Flanges

Standard on the SKG F range

Purge Ports

Removable bottom cover with flush-out connections

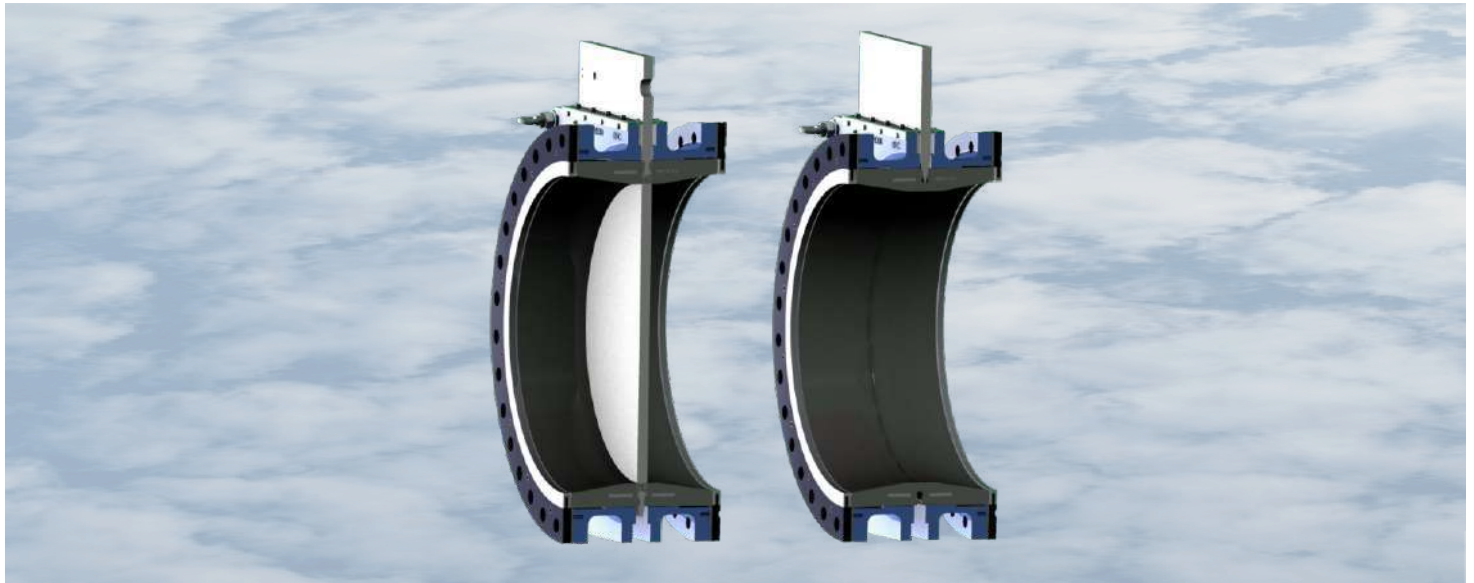

Sealing Principle

When the valve is fully opened the two identical elastomer sleeves push against each other to form a cavity free , bubble tight seal to contain the line pressure.

When the gate moves from the open to closed position, the gate separates the facing sleeves until it completely closes and seals the bore from both directions.

As the gate strokes, the gate tip creates a gap between the facing sleeves allowing media that could potentially clog or jam the valve to be purged to atmosphere.

The INSAMCOR SKG-LB valve utilizes an integrally moulded encapsulated stiffener ring to maintain the rounded shape of the sleeves under heavy shearing forces.

Specifications

Size Range

28" - 48" (DN700 - DN1200)

Pressure Rating

90PSI CWP (6 Bar)

Body & Topworks

Fusion bonded epoxy coated ductile iron body with fusion bonded epoxy coated angular support and cover plates

Sleeves

Natural rubber standard

Gate

316L standard

Retainer/Counter Flanges

Natural rubber encapsulated mild steel

Flange Drilling

MSS SP-44 Class 150 / ANSI B16.47 Class 150

AS 2129 Table D

PN6 and PN10

Optional

Pressure Rating

Optional gate materials can be used to increase the pressure rating of the INSAMCOR SKG-LB depending on the valve size and application - please consult the factory.

Gate

SAF2205 (150PSI/10 Bar), Titanium Gr-2 (75PSI/5 Bar)

Actuators

Pneumatic, electric and hydraulic

Retainer Flanges

Standard on the SKG LB range

Sleeves

EPDM

Dimensions and Weights of the SKG-F (Flanged)

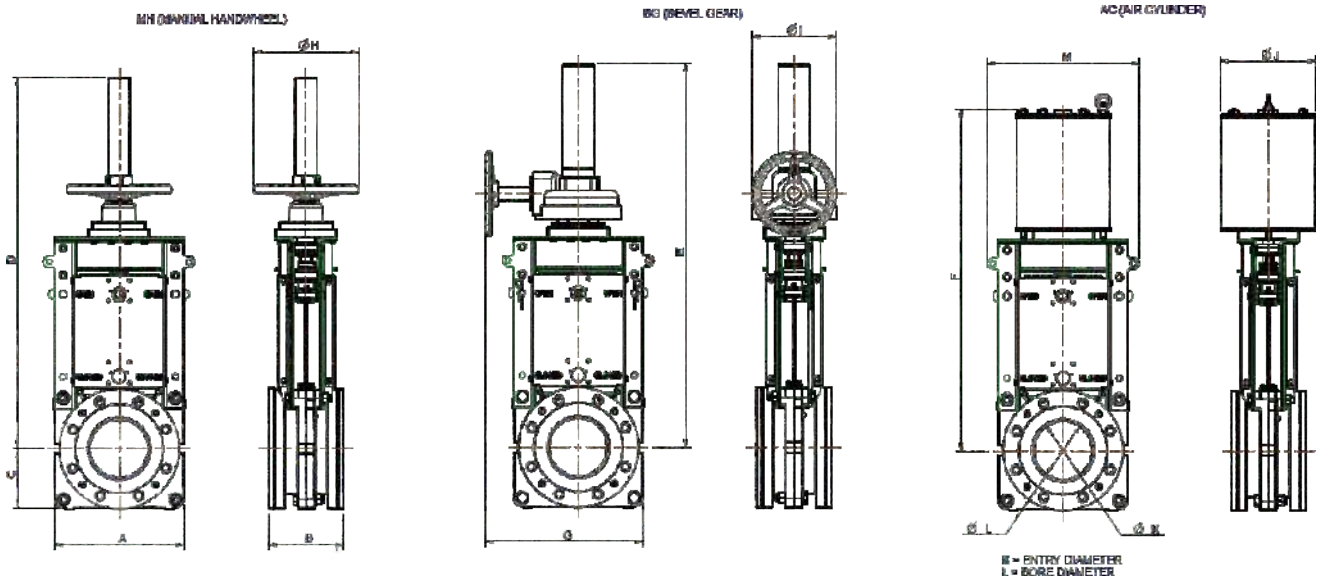

Dimensions (mm) and Weights (kg)

Valve Size	A	B	C	D	E	F	G	H	I	J	K	L	Weight MH	Weight BG	Weight AC
80	219	175	100	643	-	551	-	200	-	160	71	65	25	-	40
100	256	175	116	711	-	645	-	200	-	225	98	90	30	-	45
150	307	177	140	885	416	796	415	250	250	225	149	138	53	72	60
200	359	183	176	957	458	902	441	250	250	283	200	182	90	106	97
250	409	225	208	1167	1108	1087	466	315	315	320	252	234	95	108	148
300	481	257	244	1352	1251	1277	530	400	315	400	292	272	127	150	210
350	534	257	267	1496	1425	1372	610	400	315	485	328	305	182	205	236
400	505	280	280	1580	1619	1530	690	630	400	485	978	352	270	295	328
450	639	316	320	-	1744	1695	712	-	400	540	430	392	-	400	430
500	695	364	348	-	2240	1840	801	-	500	640	473	438	-	480	565
600	815	378	408	-	-	2180	-	-	-	640	590	540	-	-	652

Dimensions (inches) and Weights (lbs)

Valve Size	A	B	C	D	E	F	G	H	I	J	K	L	Weight MH	Weight BG	Weight AC
3	8.62	6.89	3.94	25.31	-	21.69	-	7.87	-	6.30	2.80	2.56	55	-	88
4	10.08	6.89	4.57	27.99	-	25.39	-	7.87	-	8.86	3.86	3.54	66	-	99
6	12.09	6.97	5.51	34.84	16.38	31.34	16.34	9.84	9.84	8.86	5.87	5.43	117	159	132
8	14.13	7.20	6.93	37.68	18.43	35.51	17.36	9.84	9.84	11.14	7.87	7.17	198	234	214
10	16.10	8.80	8.19	45.94	43.62	42.80	18.35	12.40	12.40	12.60	9.92	9.21	209	238	326
12	18.94	10.12	9.61	53.23	49.25	50.28	20.87	15.75	12.40	15.75	11.50	10.71	280	331	463
14	21.02	10.12	10.51	58.90	56.10	54.02	24.02	15.75	12.40	19.09	12.91	12.01	401	452	520
16	23.43	11.02	11.02	68.5	63.74	60.24	27.17	24.80	15.75	19.09	14.88	13.86	594	650	723
18	25.16	12.44	12.60	-	68.66	66.73	28.03	-	15.75	21.26	16.93	15.43	-	882	948
20	27.36	14.33	13.70	-	88.19	72.44	31.54	-	19.69	25.20	18.62	17.24	-	1058	1246
24	32.09	14.88	16.06	-	-	85.83	-	-	-	25.20	23.23	21.26	-	-	1438

Face to face dimensions (B) includes the counter / retainer flanges.



Dimensions and Weights of the SKG-W (Wafer)

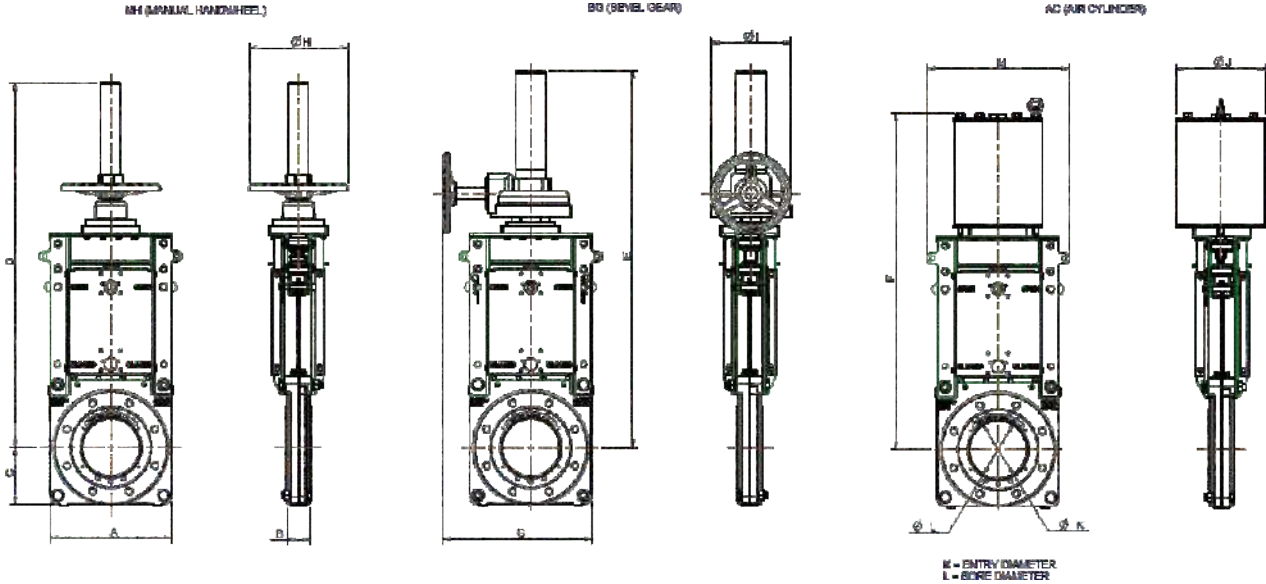

Dimensions (mm) and Weights (kg)

Valve Size	A	B1	B2	C	D	E	F	G	H	I	J	K	L	Weight MH	Weight BG	Weight AC
80	219	57	62	100	656	-	564	-	200	-	160	83	78	20	-	35
100	256	57	62	116	741	-	675	-	200	-	106	106	100	24	-	39
150	307	64	70	140	923	454	834	415	250	250	149	149	146	51	70	59
200	359	76	83	176	997	508	942	441	250	250	207	207	200	82	98	89
250	409	76	83	208	1198	1139	1118	466	315	315	251	251	248	68	90	130
300	481	83	90	244	1377	1276	1302	530	400	315	301	301	299	103	126	186
350	534	83	90	267	1544	1473	1420	610	400	315	348	348	346	145	169	200
400	595	96	103	280	1745	1709	1620	690	630	400	391	391	383	235	260	292
450	639	96	103	320	-	1804	1755	712	-	400	442	442	436	-	350	380
500	695	121	131	348	-	2310	1910	801	-	500	490	490	486	-	430	515
600	815	121	131	408	-	-	2260	-	-	-	595	595	589	-	-	602

Dimensions (inches) and Weights (lbs)

Valve Size	A	B1	B2	C	D	E	F	G	H	I	J	K	L	Weight MH	Weight BG	Weight AC
3	8.62	2.24	2.44	3.94	25.83	-	22.20	-	7.87	-	6.30	3.27	3.07	44	-	77
4	10.08	2.24	2.44	4.57	29.17	-	26.57	-	7.87	-	8.86	4.17	3.94	53	-	86
6	12.09	2.52	2.76	5.51	36.34	17.87	32.83	16.34	9.84	9.84	8.86	5.87	5.75	112	154	128
8	14.13	2.99	3.27	6.93	39.25	20.00	37.09	17.36	9.84	9.84	11.14	8.15	7.87	180	216	196
10	16.10	2.99	3.27	8.19	47.17	44.84	44.02	18.35	12.40	12.40	12.60	9.88	9.76	150	198	286
12	18.94	3.27	3.54	9.61	54.21	50.24	51.26	20.87	15.75	12.40	15.75	11.85	11.77	227	277	409
14	21.02	3.27	3.54	10.51	60.79	57.99	55.91	24.02	15.75	12.40	19.09	13.70	13.62	321	372	440
16	23.43	3.78	4.06	11.02	68.7	67.28	36.78	27.17	24.80	15.75	19.09	15.39	15.08	517	572	642
18	25.16	3.78	4.06	12.60	-	71.02	69.09	28.03	-	15.75	21.26	17.40	17.17	-	770	836
20	27.36	4.76	5.16	13.70	-	90.94	75.20	31.54	-	19.69	25.20	19.29	19.13	-	946	1133
24	32.09	4.76	5.16	16.06	-	-	88.98	-	-	-	25.20	23.43	23.19	-	-	1324

B1 = installed face-to-face dimension, B2 = recommended installation allowance

Dimensions and Weights of the SKG-LB (Large Bore)

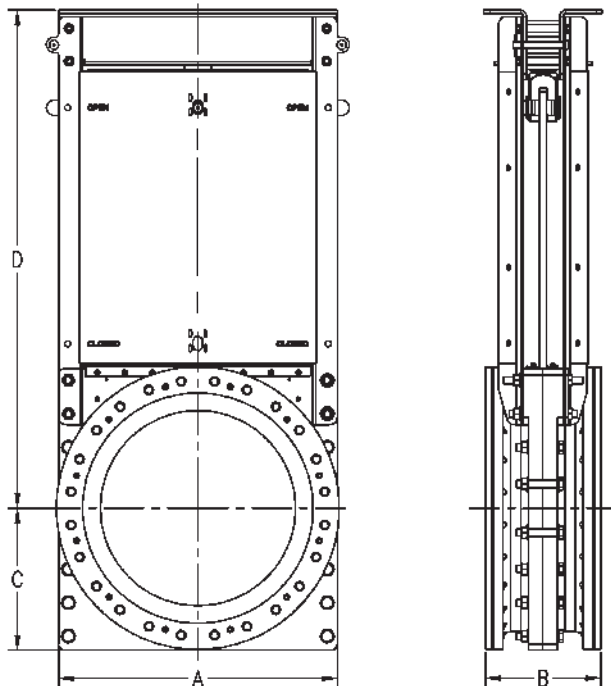

Note: For dimensions of valves equipped with pneumatic, electromechanical or hydraulic actuators, please consult the factory.

Dimensions (mm) and Weights (kg)							
Valve Size	A	B	C	D	E	F	Weight
700	915	378	466	1635	690	640	830
750	1060	395	530	1793	750	700	975
800	1060	411	530	1895	790	740	1150
900	1175	470	588	2088	890	840	1550
1000	1290	537	645	2247	990	910	2525
1200	1510	537	775	2720	1190	1100	3500

Dimensions (inches) and Weights (lbs)							
Valve Size	A	B	C	D	E	F	Weight
28	36.02	14.86	18.35	64.37	27.17	25.20	1830
30	41.73	15.55	20.87	70.59	29.53	27.56	2150
32	41.73	16.18	20.87	74.61	31.10	29.13	2535
36	46.26	18.50	23.15	82.20	35.04	33.07	3417
40	50.79	21.14	25.39	88.46	38.98	35.83	5567
48	59.45	21.14	30.51	107.09	46.85	43.31	7716

Face to face dimensions (B) includes the counter / retainer flanges.



Thrust and Torque Figures for SKG

SKG Valve Thrusts										
Pressure	PN1	PN2	PN3	PN4	PN5	PN6	PN7	PN8	PN9	PN10
Size(DN)	SKG Minimum Required Thrust (kN)									
DN80	1.0	1.2	1.4	1.6	1.8	2.0	2.2	2.4	2.6	2.8
DN100	1.2	1.5	1.8	2.1	2.4	2.7	3.0	3.3	3.6	3.9
DN150	1.6	2.2	2.9	3.6	4.3	5.0	5.6	6.3	7.0	7.7
DN200	2.4	3.6	4.8	6.0	7.3	8.5	9.7	10.9	12.1	13.3
DN250	3.4	5.3	7.2	9.1	11.0	12.9	14.8	16.7	18.6	20.5
DN300	4.7	7.4	10.1	12.8	15.6	18.3	21.0	23.7	26.5	29.2
DN350	5.8	9.5	13.2	16.9	20.6	24.3	28.0	31.7	35.4	39.1
DN400	7.8	12.6	17.4	22.3	27.1	31.9	36.8	41.6	46.5	51.3
DN450	9.2	15.3	21.4	27.6	33.7	39.8	45.9	52.1	58.2	64.3
DN500	11.6	19.2	26.8	34.3	41.9	49.4	57.0	64.6	72.1	79.7
DN600	16.7	27.6	38.5	49.4	60.3	71.2	82.1	92.9	103.8	114.7
DN700	21.3	36.1	50.9	65.7	80.5	95.3	110.2	125.0	139.8	154.6
DN750	25.3	42.3	59.3	76.3	93.3	110.3	127.3	144.3	161.8	178.3
DN800	28.2	47.5	66.9	86.2	105.6	124.9	144.3	163.6	183.0	202.3
DN900	36.2	60.7	85.2	109.7	134.2	158.6	183.1	207.6	232.1	256.6
DN1000	45.5	75.7	105.9	136.2	166.4	196.6	226.9	257.1	287.4	317.6
DN1200	65.5	109.0	152.6	196.1	239.7	283.2	326.8	370.3	413.8	457.4

SKG Valve Torques										
Pressure	PN1	PN2	PN3	PN4	PN5	PN6	PN7	PN8	PN9	PN10
Size(DN)	SKG Minimum Required Torque (Nm)									
DN80	5.2	6.2	7.2	8.1	9.1	10.1	11.0	12.0	13.0	13.9
DN100	5.8	7.3	8.8	10.3	11.8	13.4	14.9	16.4	17.9	19.4
DN150	8.7	12.4	16.2	20.0	23.8	27.5	31.3	35.1	38.8	42.6
DN200	13.4	20.1	26.8	33.5	40.2	46.9	53.6	60.3	67.0	73.7
DN250	19.1	29.6	40.0	50.5	61.0	71.5	81.9	92.4	102.9	113.3
DN300	29.8	47.1	64.4	81.7	99.0	116.3	133.6	150.9	168.2	185.6
DN350	40.9	67.2	93.4	119.6	145.9	172.1	198.3	224.6	250.8	277.0
DN400	61.2	99.5	137.7	175.9	214.2	252.4	290.6	328.8	367.1	405.3
DN450	72.7	121.1	169.5	217.9	266.3	314.6	363.0	411.4	459.8	508.2
DN500	100.4	165.6	230.8	295.9	361.1	426.3	491.5	556.7	621.9	687.1
DN600	180.8	298.4	416.1	533.7	651.3	768.9	886.5	1004.1	1121.7	1239.3
DN700	168.0	285.1	402.2	519.2	636.3	753.4	870.5	987.5	1104.6	1221.7
DN750	217.9	364.5	511.2	657.9	804.6	951.3	1097.9	1244.6	1391.3	1538.0
DN800	242.8	409.7	576.6	743.5	910.4	1077.2	1244.1	1411.0	1577.9	1744.8
DN900	341.6	572.9	804.2	1035.5	1266.8	1498.1	1729.3	1960.6	2191.9	2423.2
DN1000	491.1	817.8	1144.5	1471.2	1797.9	2124.5	2451.2	2777.9	3104.6	3431.3
DN1200	832.3	1385.6	1938.8	2492.1	3045.4	3598.6	4151.9	4705.1	5258.4	5811.7

Applications

In-house developed and manufactured sleeves and elastomers, coupled with more than 40 years' experience in polymer and rubber technology, ensure consistent quality and superior abrasion resistance in a wide range of mineral processing applications.

INSAMCOR's range of elastomers have a proven track record and were developed to maximize rebound resilience and elastic recovery to improve abrasion resistance and sealing performance in mineral processing slurries.

The INSAMCOR SKG was developed and refined in conjunction with mineral processing end-users to solve the problems typically experienced in harsh mining conditions.

DFC has one of the largest installed bases of mineral processing valves in the world and manufacturing facilities in South Africa, Finland and the USA. With sales and support facilities in Australia, North and South America, Europe, Asia, the Middle East and Africa, DFC's staff and agents are readily available and committed to solving your problems and providing you with the best possible service wherever your business is located.

INSAMCOR SKGs are used in a wide array of industries and applications. Examples include:

Mining Industry

- ✓ Grinding
- ✓ Size separation - hydro cyclones
- ✓ Process water
- ✓ Flotation
- ✓ Thickening
- ✓ Tailings discharge
- ✓ Water reclamation

Coal Fired Power Plants

- ✓ Lime slurry
- ✓ Fly ash slurry
- ✓ Scrubber slurry
- ✓ Bottom ash
- ✓ FGD systems

Other industries

- ✓ Coal washing
- ✓ Steel
- ✓ Cement
- ✓ Chemical
- ✓ Phosphates



Platinum Slurry



IsaMill™ Inlet



Uranium Slurry



Coal Washing Plant

Elastomer Qualities Selection

Elastomer Type	Natural Rubber	Ethylene Propylene	Fluorocarbon	Nitrile
Abbreviation	NR	EPDM	FKM/FPM	NBR
Max continuous operating temp. (F)	190	300	390	200
Max continuous operating temp. (C)	88	149	199	93
Abrasion resistance	Excellent	Very Good	Good	Good
Generally resistant to	Moderate Chemicals, Organic Acids, Alcohols, Ketones, Aldehydes	Animal and Vegetable oils, Ozone, Strong & Oxidizing Chemicals	All Aliphatic, Aromatic & Halogenated Hydrocarbons, Acids, Oils	Many Hydrocarbons, Fats, Oils, Greases, Hydraulic Fluids, Chemicals
Generally attacked by	Ozone, Strong Acids, Fats, Oils, Greases, Most Hydrocarbons	Mineral Oils & Solvents, Aromatic Hydrocarbons	Ketones, Esters & Nitro containing compounds	Ozone, Ketones, Esters, Aldehydes, Chlorinated & Nitro Hydrocarbons

Other DFC World Class Performance Related Valves

RF Valve® and aiRFlex® pinch valves

The world's most complete line of pinch valves in standard ASME/ANSI B16, DIN and ISO face-to-face dimensions from 1" to 60" (DN25 to Dn1500).

- ✓ Patented non-stretch, anti-stress folds in all elastomer tubes
- ✓ In-line elastomer tube change capability without removing the valve from the pipeline
- ✓ Most advanced wear sensing technology for preventative maintenance alert



Insamcor® MH and MLB slurry valves

Bi-directional wafer mono-flange knife gate valves suitable for end-of-line installation

- ✓ Combination primary transverse seal and secondary stuffing box seal for severe applications
- ✓ Mechanically retained moulded seat with no seat pockets
- ✓ MH sizes 2" to 24" (DN50 to DN600)
- ✓ MLB sizes 28" to 48" (DN700 to DN1200)



Insamcor® LW semi-lugged slurry valves

Bi-directional wafer semi-lugged knife gate valve designed for slurry applications.

- ✓ Stuffing box seal to atmosphere
- ✓ Mechanically retained moulded seat with no seat pockets
- ✓ Self-cleaning flush out corners prevent slurry build-up in sealing area
- ✓ Easy mounting of proximity or limit switches
- ✓ Sizes 2" to 24" (DN50 to DN600)



Saunders® A Type and KB Type diaphragm valves

Simplicity in design coupled with more than 75 years of cutting edge innovation has resulted in the Saunders diaphragm's ability to handle a wider range of fluids than any other valve type.

- ✓ Available in weir and straight through type
- ✓ Available in either flanged or screwed ends
- ✓ Various lining and diaphragm material options



DFC manufactures this range under license from CPFT Ltd and is only available in selected African countries

The Americas Operations

RF Valves Inc.
1342-A Charwood Road
Hanover, MD 21076, USA
Tel: +1-410-850-4404 Fax: +1-410-850-4464
Email: contact@rfvalve.com
Website: www.rfvalve.com

African Operations

Dynamic Fluid Control (Pty) Ltd
32 Lincoln Road,
Industrial Sites, Benoni South, South Africa
Tel: +27-11-748-0200 Fax: +27-11-421-2749
Email: dfc@dfc.co.za
Website: www.dfc.co.za

Australian Operations - NSW

Vent-O-Mat Australia
5 Vangeli St, Arndell Park, NSW, 2148
P.O. Box 156, Seven Hills, NSW, 1730
Tel: +61-2-8814-9699
Fax: +61-2-8814-9666
Email: sales@ventomat.com.au
Website: www.ventomat.com.au

European Operations

RF Valves, Oy.
Tullitie 9,
53500 Lappeenranta, Finland
Tel: +358-20-758-1790 Fax: +358-20-785-1799
Email: rfvalves@rftek.fi
Website: www.rfvalve.com

Brazil Operations

DFC Brasil
Industria e Comercio de Valvulas do Brasil Ltda
Address: Rua Álvaro da Silveira, 40 - Santa Margarida
Belo Horizonte - Minas Gerais, Brasil
Tel : +55-31-3658-3656
Email address: rfq@rfvalve.com
Website: www.rfvalve.com